

1			2				3				4		
A	100K/M20-St/St	35	16	5	100	13	85	7	M20	30	17	18000N (1800kg)	A
	100/M20-St/St	35	16	-	100	-	-	-	M20	30	17	18000N (1800kg)	
	80K/M20-St/St	35	16	5	80	13	65	7	M20	30	17	18000N (1800kg)	
	80/M20-St/St	35	16	-	80	-	-	-	M20	30	17	18000N (1800kg)	
	60K/M20-St/St	35	16	5	60	13	45	7	M20	30	17	18000N (1800kg)	
	60/M20-St/St	35	16	-	60	-	-	-	M20	30	17	18000N (1800kg)	
	50/M20-St/St	35	16	-	50	-	-	-	M20	30	17	18000N (1800kg)	
	40/M20-St/St	35	16	-	40	-	-	-	M20	30	17	18000N (1800kg)	
	30/M20-St/St	35	16	-	30	-	-	-	M20	30	17	10600N (1060kg)	
B	100K/M16-St/St	32	15	5	100	13	85	7	M16	24	13	10000N (1000kg)	B
	100/M16-St/St	32	15	-	100	-	-	-	M16	24	13	10000N (1000kg)	
	80K/M16-St/St	32	15	5	80	13	65	7	M16	24	13	10000N (1000kg)	
	80/M16-St/St	32	15	-	80	-	-	-	M16	24	13	10000N (1000kg)	
	60K/M16-St/St	32	15	5	60	13	45	7	M16	24	13	10000N (1000kg)	
	60/M16-St/St	32	15	-	60	-	-	-	M16	24	13	10000N (1000kg)	
	50K/M16-St/St	32	15	5	50	13	35	7	M16	24	13	10000N (1000kg)	
	50/M16-St/St	32	15	-	50	-	-	-	M16	24	13	10000N (1000kg)	
	40/M16-St/St	32	15	-	40	-	-	-	M16	24	13	10000N (1000kg)	
C	30/M16-St/St	32	15	-	30	-	-	-	M16	24	13	10000N (1000kg)	C
	20/M16-St/St	32	15	-	20	-	-	-	M16	24	13	2750N (275kg)	
	100K/M14-St/St	30	15	5	100	13	85	7	M14	22	11	6500N (650kg)	
	100/M14-St/St	30	15	-	100	-	-	-	M14	22	11	6500N (650kg)	
	80K/M14-St/St	30	15	5	80	13	65	7	M14	22	11	6500N (650kg)	
	80/M14-St/St	30	15	-	80	-	-	-	M14	22	11	6500N (650kg)	
	60K/M14-St/St	30	15	5	60	13	45	7	M14	22	11	6500N (650kg)	
	60/M14-St/St	30	15	-	60	-	-	-	M14	22	11	6500N (650kg)	
	50K/M14-St/St	30	15	5	50	13	35	7	M14	22	11	6500N (650kg)	
D	50/M14-St/St	30	15	-	50	-	-	-	M14	22	11	6500N (650kg)	D
	40/M14-St/St	30	15	-	40	-	-	-	M14	22	11	6500N (650kg)	
	30/M14-St/St	30	15	-	30	-	-	-	M14	22	11	6500N (650kg)	
	20/M14-St/St	30	15	-	20	-	-	-	M14	22	11	2750N (275kg)	
	100K/M12-St/St	26	14	5	100	13	85	7	M12	19	10	4100N (410kg)	
	100/M12-St/St	26	14	-	100	-	-	-	M12	19	10	4100N (410kg)	
	80K/M12-St/St	26	14	5	80	13	65	7	M12	19	10	4100N (410kg)	
	80/M12-St/St	26	14	-	80	-	-	-	M12	19	10	4100N (410kg)	
	60K/M12-St/St	26	14	5	60	13	45	7	M12	19	10	4100N (410kg)	
E	60/M12-St/St	26	14	-	60	-	-	-	M12	19	10	4100N (410kg)	E
	50K/M12-St/St	26	14	5	50	13	35	7	M12	19	10	4100N (410kg)	
	50/M12-St/St	26	14	-	50	-	-	-	M12	19	10	4100N (410kg)	
	40/M12-St/St	26	14	-	40	-	-	-	M12	19	10	4100N (410kg)	
	30/M12-St/St	26	14	-	30	-	-	-	M12	19	10	4100N (410kg)	
	20/M12-St/St	26	14	-	20	-	-	-	M12	19	10	2750N (275kg)	
	100K/M10-St/St	25	14	5	100	13	85	7	M10	17	8	1400N (140kg)	
	100/M10-St/St	25	14	-	100	-	-	-	M10	17	8	1400N (140kg)	
	80K/M10-St/St	25	14	5	80	13	65	7	M10	17	8	1400N (140kg)	
F	80/M10-St/St	25	14	-	80	-	-	-	M10	17	8	1400N (140kg)	F
	60K/M10-St/St	25	14	5	60	13	45	7	M10	17	8	1400N (140kg)	
	60/M10-St/St	25	14	-	60	-	-	-	M10	17	8	1400N (140kg)	
	50K/M10-St/St	25	14	5	50	13	35	7	M10	17	8	1400N (140kg)	
	50/M10-St/St	25	14	-	50	-	-	-	M10	17	8	1400N (140kg)	
	40/M10-St/St	25	14	-	40	-	-	-	M10	17	8	1400N (140kg)	
	30/M10-St/St	25	14	-	30	-	-	-	M10	17	8	1400N (140kg)	
	20/M10-St/St	25	14	-	20	-	-	-	M10	17	8	1400N (140kg)	
	OZNAČENÍ	A	B	C	D	E	F	G	M	S1	S2	cena	

NOHA STAVITELNÁ - VÝKYVNÁ M10-M20, OCELOVÁ

1

2

3

4

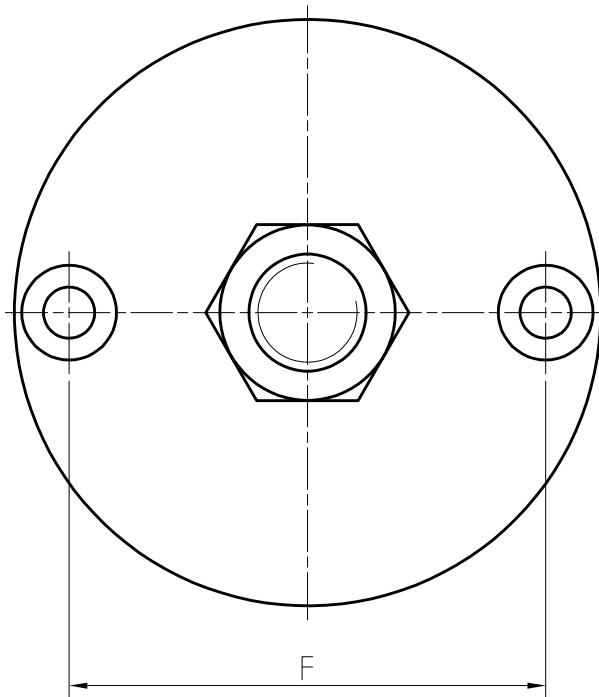
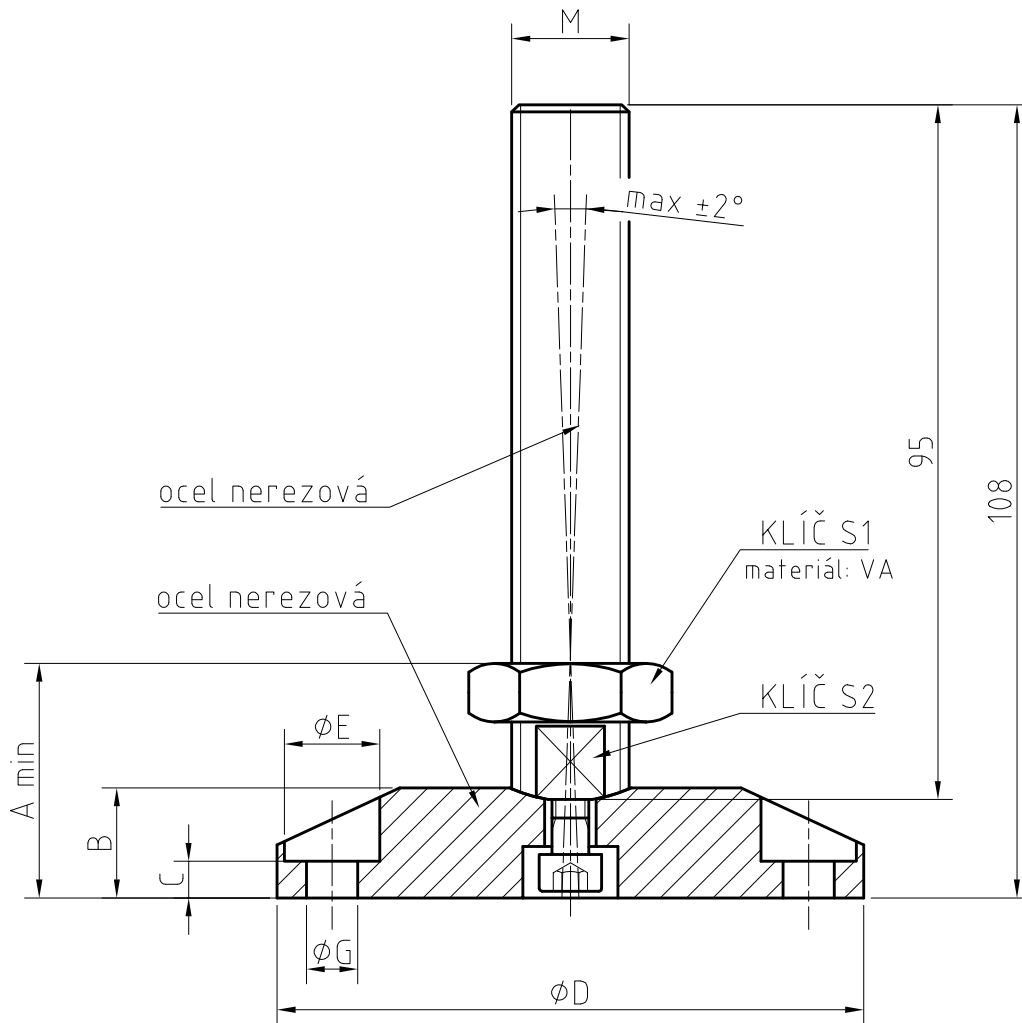

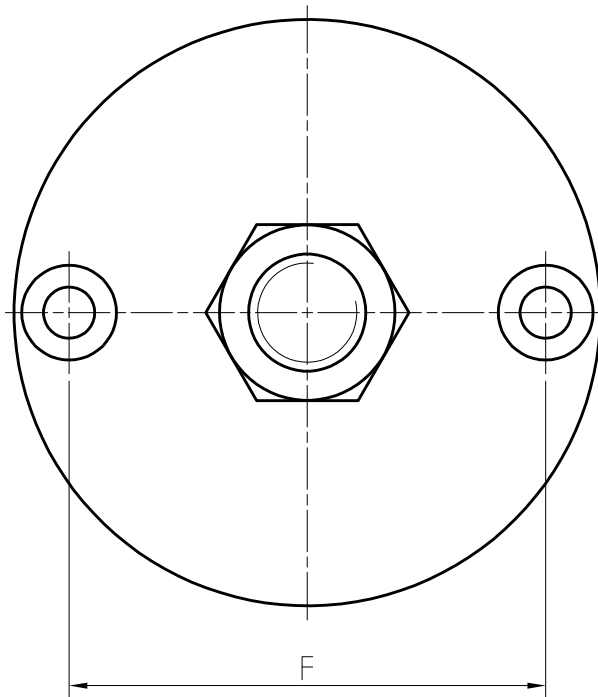
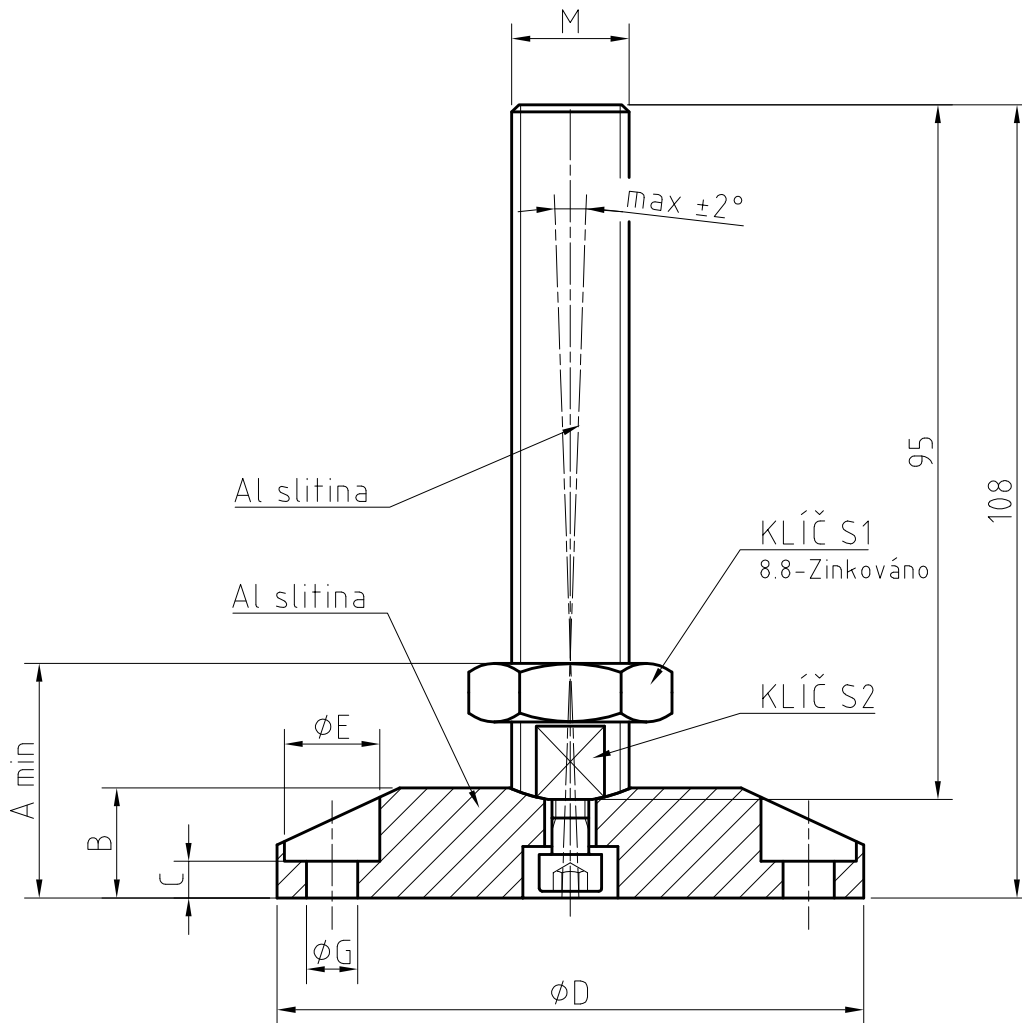

1				2				3				4			
A	100K/M20-Al/Al	35	16	5	100	13	85	7	M20	30	17		15000N (1500kg)	A	
	100/M20-Al/Al	35	16	-	100	-	-	-	M20	30	17		15000N (1500kg)		
	80K/M20-Al/Al	35	16	5	80	13	65	7	M20	30	17		15000N (1500kg)		
	80/M20-Al/Al	35	16	-	80	-	-	-	M20	30	17		15000N (1500kg)		
	60K/M20-Al/Al	35	16	5	60	13	45	7	M20	30	17		15000N (1500kg)		
	60/M20-Al/Al	35	16	-	60	-	-	-	M20	30	17		15000N (1500kg)		
	50/M20-Al/Al	35	16	-	50	-	-	-	M20	30	17		15000N (1500kg)		
	40/M20-Al/Al	35	16	-	40	-	-	-	M20	30	17		15000N (1500kg)		
	30/M20-Al/Al	35	16	-	30	-	-	-	M20	30	17		10600N (1060kg)		
B	100K/M16-Al/Al	32	15	5	100	13	85	7	M16	24	13		8300N (830kg)	B	
	100/M16-Al/Al	32	15	-	100	-	-	-	M16	24	13		8300N (830kg)		
	80K/M16-Al/Al	32	15	5	80	13	65	7	M16	24	13		8300N (830kg)		
	80/M16-Al/Al	32	15	-	80	-	-	-	M16	24	13		8300N (830kg)		
	60K/M16-Al/Al	32	15	5	60	13	45	7	M16	24	13		8300N (830kg)		
	60/M16-Al/Al	32	15	-	60	-	-	-	M16	24	13		8300N (830kg)		
	50K/M16-Al/Al	32	15	5	50	13	35	7	M16	24	13		8300N (830kg)		
	50/M16-Al/Al	32	15	-	50	-	-	-	M16	24	13		8300N (830kg)		
	40/M16-Al/Al	32	15	-	40	-	-	-	M16	24	13		8300N (830kg)		
	30/M16-Al/Al	32	15	-	30	-	-	-	M16	24	13		8300N (830kg)		
C	20/M16-Al/Al	32	15	-	20	-	-	-	M16	24	13		2750N (275kg)	C	
	100K/M14-Al/Al	30	15	5	100	13	85	7	M14	22	11		5200N (520kg)		
	100/M14-Al/Al	30	15	-	100	-	-	-	M14	22	11		5200N (520kg)		
	80K/M14-Al/Al	30	15	5	80	13	65	7	M14	22	11		5200N (520kg)		
	80/M14-Al/Al	30	15	-	80	-	-	-	M14	22	11		5200N (520kg)		
	60K/M14-Al/Al	30	15	5	60	13	45	7	M14	22	11		5200N (520kg)		
	60/M14-Al/Al	30	15	-	60	-	-	-	M14	22	11		5200N (520kg)		
	50K/M14-Al/Al	30	15	5	50	13	35	7	M14	22	11		5200N (520kg)		
	50/M14-Al/Al	30	15	-	50	-	-	-	M14	22	11		5200N (520kg)		
	40/M14-Al/Al	30	15	-	40	-	-	-	M14	22	11		5200N (520kg)		
D	30/M14-Al/Al	30	15	-	30	-	-	-	M14	22	11		5200N (520kg)	D	
	20/M14-Al/Al	30	15	-	20	-	-	-	M14	22	11		2750N (275kg)		
	100K/M12-Al/Al	26	14	5	100	13	85	7	M12	19	10		3300N (330kg)		
	100/M12-Al/Al	26	14	-	100	-	-	-	M12	19	10		3300N (330kg)		
	80K/M12-Al/Al	26	14	5	80	13	65	7	M12	19	10		3300N (330kg)		
	80/M12-Al/Al	26	14	-	80	-	-	-	M12	19	10		3300N (330kg)		
	60K/M12-Al/Al	26	14	5	60	13	45	7	M12	19	10		3300N (330kg)		
	60/M12-Al/Al	26	14	-	60	-	-	-	M12	19	10		3300N (330kg)		
	50K/M12-Al/Al	26	14	5	50	13	35	7	M12	19	10		3300N (330kg)		
	50/M12-Al/Al	26	14	-	50	-	-	-	M12	19	10		3300N (330kg)		
E	40/M12-Al/Al	26	14	-	40	-	-	-	M12	19	10		3300N (330kg)	E	
	30/M12-Al/Al	26	14	-	30	-	-	-	M12	19	10		3300N (330kg)		
	20/M12-Al/Al	26	14	-	20	-	-	-	M12	19	10		2750N (275kg)		
	100K/M10-Al/Al	25	14	5	100	13	85	7	M10	17	8		1100N (110kg)		
	100/M10-Al/Al	25	14	-	100	-	-	-	M10	17	8		1100N (110kg)		
	80K/M10-Al/Al	25	14	5	80	13	65	7	M10	17	8		1100N (110kg)		
	80/M10-Al/Al	25	14	-	80	-	-	-	M10	17	8		1100N (110kg)		
	60K/M10-Al/Al	25	14	5	60	13	45	7	M10	17	8		1100N (110kg)		
	60/M10-Al/Al	25	14	-	60	-	-	-	M10	17	8		1100N (110kg)		
	50K/M10-Al/Al	25	14	5	50	13	35	7	M10	17	8		1100N (110kg)		
F	50/M10-Al/Al	25	14	-	50	-	-	-	M10	17	8		1100N (110kg)	F	
	40/M10-Al/Al	25	14	-	40	-	-	-	M10	17	8		1100N (110kg)		
	30/M10-Al/Al	25	14	-	30	-	-	-	M10	17	8		1100N (110kg)		
	20/M10-Al/Al	25	14	-	20	-	-	-	M10	17	8		1100N (110kg)		
	OZNAČENÍ	A	B	C	D	E	F	G	M	S1	S2	cena	doporučené max. zatížení F[N] (kg)		

NOHA STAVITELNÁ - VÝKYVNÁ M10-M20, HLÍŇÍKOVÁ

1

2

3

4

